

Single-mode Passive Fiber Network TAP

1G/10G/25G/40G/100G | Portable



Network test access points (TAPs) are hardware tools that allow you to monitor your network. All fiber breakout TAPs are passive, purpose-built hardware devices that make a 100% copy of your network's data allowing your monitoring tools to see every bit, byte and packet.®

Passive TAPs are non-powered devices that will not cause the live network devices to lose link between one another if power is lost.

Key Features

- 100% network visibility
- 100% secure and invisible; no IP address; no Mac address; cannot be hacked
- Passes physical layer errors
- Supports Breakout Mode
- Supports Jumbo frames
- TAPs constructed with durable, crush-resistant materials (metal)
- 1U rack mount kit holds up to 4 modules, each module can have 1, 2, 3 or 4 TAPs
- Plug & Play easy installation, no configuration; no power source required
- Made, tested and certified in the USA

Network Flow

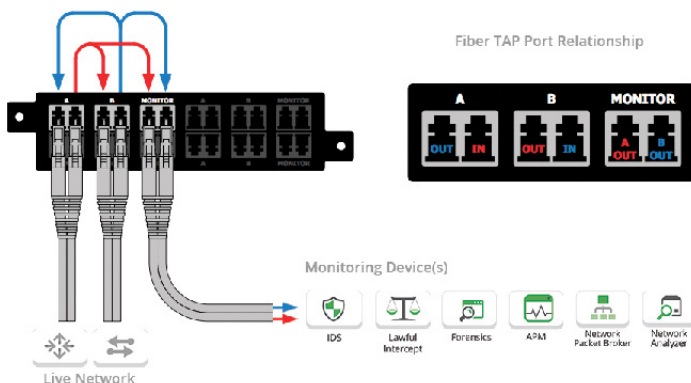

APPLICATIONS:

- Network & Application Monitoring
- Network & Application Analysis
- Network & Application Performance
- Data Center-Longhaul fiber environment

+ Breakout Mode is ideal when utilization is very high and packet loss is not an option.

SOLUTIONS:

Passive optical TAPs are ideal for:

- IDS Intrusion Detection Systems
- APM Application Performance Monitoring
- Lawful Intercept Lawful Interception
- Packet Capture Packet Capture
- DPI Deep Packet Inspection
- Network Analyzer Network Analyzer
- Forensics Forensics

Competitive Edge

















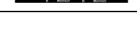

- No upgrade needed. Unlike the competition, this handles your network today and tomorrow, and will work in all of your applications.
- Supports long range and extended range single-mode environments.
- Tested and Certified



Have Questions?

sales@garlandtechnology.com
+716.242.8500
garlandtechnology.com

Single-mode Passive Fiber Network TAP 1G/10G/25G/40G/100G | Portable

Model #	Network Speed	Ports	# of TAPS	Split Ratio*	Wavelengths	Media	Connector/Mode
RMP-1U			1U Rack Mount Kit - Hold up to 4 Modules, each Module can have 1, 2, 3 or 4 TAPs				
OS1501	Up to 100G		1	50/50	1310/1550nm	Fiber-OS1	Fiber-LC Single-Mode Fiber
OS1701	Up to 100G		1	70/30	1310/1550nm	Fiber-OS1	Fiber-LC Single-Mode Fiber
OS2501	Up to 100G		1	50/50	1310/1550nm	Fiber-OS2	Fiber-LC Single-Mode Fiber
OS2701	Up to 100G		1	70/30	1310/1550nm	Fiber-OS2	Fiber-LC Single-Mode Fiber
OS1502	Up to 100G		2	50/50	1310/1550nm	Fiber-OS1	Fiber-LC Single-Mode Fiber
OS1702	Up to 100G		2	70/30	1310/1550nm	Fiber-OS1	Fiber-LC Single-Mode Fiber
OS2502	Up to 100G		2	50/50	1310/1550nm	Fiber-OS2	Fiber-LC Single-Mode Fiber
OS2702	Up to 100G		2	70/30	1310/1550nm	Fiber-OS2	Fiber-LC Single-Mode Fiber
OS2702-BiDi	1/10		2	70/30	1270-1350nm/ 1450-1530nm/ 1510-1590nm	Fiber-OS2	Fiber-LC Single-mode Fiber
OS1503	Up to 100G		3	50/50	1310/1550nm	Fiber-OS1	Fiber-LC Single-Mode Fiber
OS1703	Up to 100G		3	70/30	1310/1550nm	Fiber-OS1	Fiber-LC Single-Mode Fiber
OS2503	Up to 100G		3	50/50	1310/1550nm	Fiber-OS2	Fiber-LC Single-Mode Fiber
OS2703	Up to 100G		3	70/30	1310/1550nm	Fiber-OS2	Fiber-LC Single-Mode Fiber
OS1504	Up to 100G		4	50/50	1310/1550nm	Fiber-OS1	Fiber-LC Single-Mode Fiber
OS1704	Up to 100G		4	70/30	1310/1550nm	Fiber-OS1	Fiber-LC Single-Mode Fiber
OS2504*	Up to 100G		4	50/50	1310/1550nm	Fiber-OS2	Fiber-LC Single-Mode Fiber
OS2704*	Up to 100G		4	70/30	1310/1550nm	Fiber-OS2	Fiber-LC Single-Mode Fiber
CTAP4-20M45-20S25	1/10G		4	50/50 50/50	MM 850nm SM 1310/1550nm	Fiber-OM4 Fiber OS2	LC-Multi-Mode Fiber LC-Single-Mode Fiber

*Custom split ratios are available in 60/40, 80/20 or 90/10, please inquire.

Additional Specifications

Optical Fiber Insertion Loss for OS1, OS2 with 1310/1550nm

Splitter: Single-Mode (OS1, OS2) with LC Connector*			Splitter: Single-Mode (OS1, OS2) with LC Connector*		
Split Ratio	Network Port	Monitor Port	Split Ratio	Network Port	Monitor Port
50/50	3.6 dB	3.6 dB	50/50	3.6 dB	3.6 dB
70/30	1.9 dB	5.8 dB	70/30	1.9 dB	5.8 dB

* Measured loss through splitter only ** Measured loss through splitter; plus one mated pair (two fibers terminated and connected together with a fiber optic coupler). For methodology read: Tech Notes on [Measuring Budget Light Loss](#).

Single mode

Fiber Type: Corning 9/125 micron
Directivity: ≥50dB
Temperature: -40 to +85C
Packaging: Stainless steel tube, 3.05mm (dia) x 55mm (len)

Additional

Dimensions: (HxWxD): 1.72" x 3.9" x 6.8" (43.69mm x 99.06mm x 172.72mm)
Weight: 1.45 lbs (0.66 kg)
Ambient Temperature: 0C to +40C / +32F to +104F
Storage Temperature: -20C to +70C / -4F to +158F
Humidity: 90% non-condensing
 *There is no power needed for these TAPs



This document is for informational purposes only. The information in this document, believed by Garland Technology to be accurate as of the date of publication, is subject to change without notice. Garland Technology assumes no responsibility for any errors or omissions in this document and shall have no obligation to you as a result of having made this document available to you or based upon the information it contains. ©2019 Garland Technology LLC. All Rights Reserved